



GRADE 4 SUPPLEMENT

Set D6 Measurement: Area & Perimeter

Includes

Activity 1: Measuring Area	D6.1
Activity 2: Measuring Perimeter	D6.9
Activity 3: The Ladybugs' Garden	D6.15
Activity 4: Hexarights	D6.21
Independent Worksheet 1: Area & Perimeter Review	D6.29
Independent Worksheet 2: Measuring Rectangles	D6.33

Skills & Concepts

- ★ determine the perimeters and areas of squares and other rectangles using formulas and explain why the formulas work
- ★ determine the areas of nonrectangular figures that can be composed or decomposed into rectangles
- ★ demonstrate that rectangles with the same area can have different perimeters, and that rectangles with the same perimeter can have different areas
- ★ solve single- and multi-step contextual problems involving perimeters and areas, and justify the solutions

Bridges in Mathematics Grade 4 Supplement

Set D6 Measurement: Area & Perimeter

The Math Learning Center, PO Box 12929, Salem, Oregon 97309. Tel. 1 800 575–8130.

© 2008 by The Math Learning Center

All rights reserved.

Prepared for publication on Macintosh Desktop Publishing system.

Printed in the United States of America.

P1211

The Math Learning Center grants permission to classroom teachers to reproduce blackline masters in appropriate quantities for their classroom use.

Bridges in Mathematics is a standards-based K–5 curriculum that provides a unique blend of concept development and skills practice in the context of problem solving. It incorporates the Number Corner, a collection of daily skill-building activities for students.

The Math Learning Center is a nonprofit organization serving the education community. Our mission is to inspire and enable individuals to discover and develop their mathematical confidence and ability. We offer innovative and standards-based professional development, curriculum, materials, and resources to support learning and teaching. To find out more, visit us at www.mathlearningcenter.org.

Set D6 ★ Activity 1



ACTIVITY

Measuring Area

Overview

Students review the term area and work together to generate a formula for determining the area of rectangles and squares. In the process, they have an opportunity to see and handle a square inch and a square foot. Then they apply the information as they work in pairs to find the area of various items around the classroom.

Skills & Concepts

- ★ determine the perimeters and areas of squares and other rectangles using formulas and explain why the formulas work

You'll need

- ★ Measuring Area (page D6.4, run a class set)
- ★ one 12" × 12" piece of red construction paper
- ★ 10" × 18" blue construction paper (1 piece for every 4 students)
- ★ rulers (class set)
- ★ yardsticks and measuring tapes
- ★ masking tape
- ★ calculators (optional, class set)
- ★ Student Math Journals or 1 piece of lined or grid paper per student
- ★ Word Resource Cards *Area, Dimension* (pages D6.5 and D6.6 & D6.7 and D6.8, run 1 copy back to back on cardstock, cut out each card)

Instructions for Measuring Area

1. Post the Word Resource Card for *area* on the board. Ask students to pair-share what they know about this term. After a minute or two, invite volunteers to share their ideas with the class. As the discussion unfolds, review the following concepts:

- area is a measure of how much surface something takes up.
- area is measured in square units such as square inches, square feet, or square miles.



2. Hold up a single tile and ask students to report its area in square inches. If necessary, have a volunteer measure the dimensions of the tile and work with the class to establish the fact that it's exactly 1 square inch. Use a loop of masking tape to fasten the tile to the board. Work with class input to label its dimensions and area.

3. Distribute sets of tile. Ask students to work in groups of four to build a square with an area of exactly 144 square inches. After they've had a few minutes to work, have them share and compare their results.

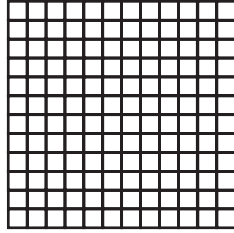
Activity 1 Measuring Area (cont.)

Students *We thought it was going to be really big, but it's not so big after all.*

We knew it was going to be a 12" × 12" square because 12 × 12 is 144.

We each made 3 rows of 12 and put them together. It went pretty fast for us.

4. Ask each group to measure the dimensions of the square they've just built with the inch side of their ruler. What can they tell you about the square now? As volunteers share with the class, press them to explain their thinking.

Alex *It's 12 inches on both sides.*

Teacher *What is the area of your square, and how do you know?*

Students *It's 144 square inches because that's what you told us to do.*

It's 144 square inches because we used 144 tiles, and each tile is 1 square inch.

You can see a 10 × 10 square inside the 12 × 12. Then just add 12 on the top and bottom, and 10 on both sides. It makes 144 in all.

It's 12 rows of 12. If you just multiply 12 × 12, you get 144.

5. Show students the 12" × 12" square of red construction paper you've prepared. Ask a volunteer to compare the paper to the tile square at his or her table. After confirming that the two are the same size, fasten the paper square to the board. Work with class input to label its dimensions and area. Explain that because it is 12" or 1 foot on each side, it's called a square foot, and record this information on the board.

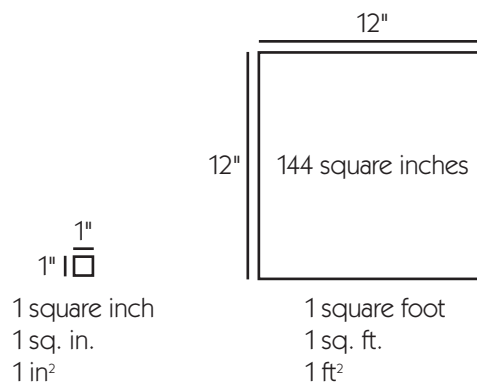

6. Give each group a 10" × 18" piece of blue construction paper. Ask them to find the area of this rectangle, using their rulers and/or the tile to help. Challenge them to find a more efficient method than covering the entire rectangle with tile. Have them each record the answer, along with any computations they made, in their journals.

7. When they've had a few minutes to work, ask students to share their answers and explain how they found the area of the rectangle. Record their strategies at the board.

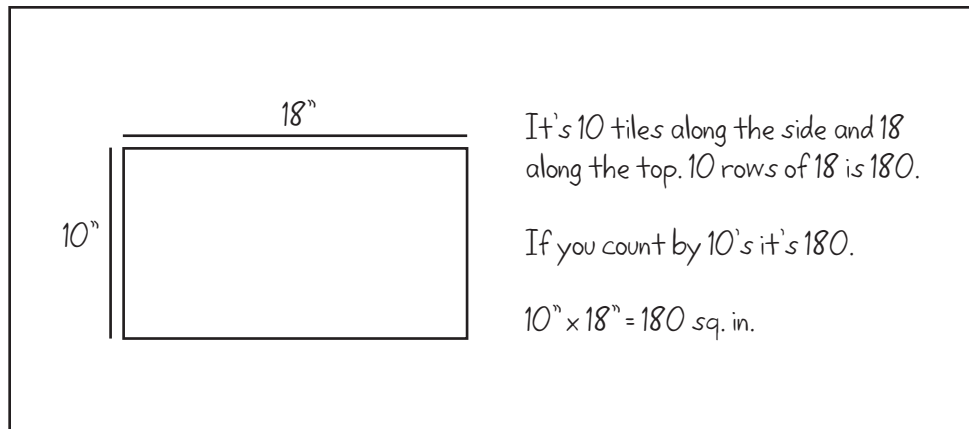
Activity 1 Measuring Area (cont.)

8. Chances are, some students will have compared the paper rectangle to the tile square at their table to find the side lengths, and then used some kind of counting strategy to find the area. Others may have done the same but multiplied the dimensions to find the area. Still others may have measured the dimensions with their rulers and multiplied. If the third strategy doesn't come from the students, tape one of the 10" × 18" pieces of paper to the board and model it yourself.

9. Post the Word Resource Card for *dimension* on the board. Explain that to find the area of a square or a rectangle, we measure its dimensions and multiply the 2 numbers. Press students to explain how and why this works, and then work with input from the class to write the general formula for the area of a rectangle: area = length × width or $A = lw$.

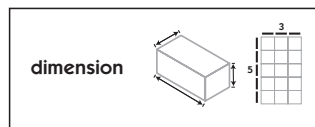

10. Explain that in a minute, students will be working in pairs to find the area of some things around the classroom. Ask them to look around. Can they spot anything they'd measure in square inches? What about the calendar grid pocket chart or the whiteboard? Would they find the area of these in square inches or square feet?

Students *I'd use square inches to find out the area of small stuff like my math journal or probably my desk.*

I'd maybe use square feet instead of square inches to get the area of the calendar chart.

I'd definitely use square feet to measure the area of the rug or the whole room.

11. Give students each a copy of the Measuring Area worksheet. Examine the chart together and explain the tasks as needed. Make sure they know where to find the yardsticks and measuring tapes as they need them. Then ask them to work in pairs to complete the sheet.

Note *Advise students to work to the nearest inch in measuring the dimensions of the items listed on the worksheet. You might also allow them to use calculators to help with the computation, especially if some of your students aren't yet completely fluent with 2-digit by 2-digit multiplication.*

NAME _____

DATE _____

Measuring Area

Find the area of each item listed below.	Dimensions (Measure to the nearest inch and show your units: inches or feet)	Area (Show your work and label the answer with the correct units.)
example A piece of blue construction paper	Length = 18" Width = 10"	$18'' \times 10'' = 180 \text{ sq. in.}$
1 Your math journal		
2 Your desk or table		
3 A geoboard		
4 Calendar Grid pocket chart		
5 The top of a bookshelf		
6 The front of a chapter book		
7 A Calendar Grid marker		
8 A work table larger than the one where you sit		
9 The whiteboard		
 10 The classroom		

area

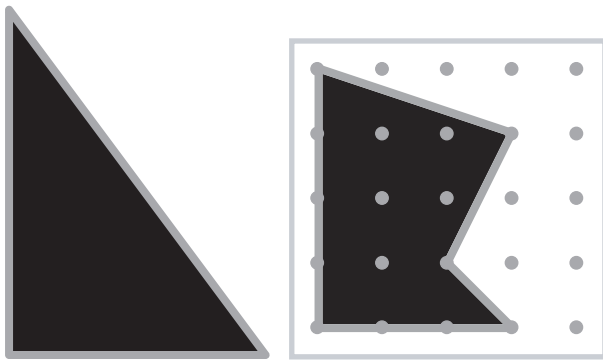

Bridges in Mathematics

© The Math Learning Center

Working Definition

**area: the total number of square units
needed to cover a 2-dimensional surface**

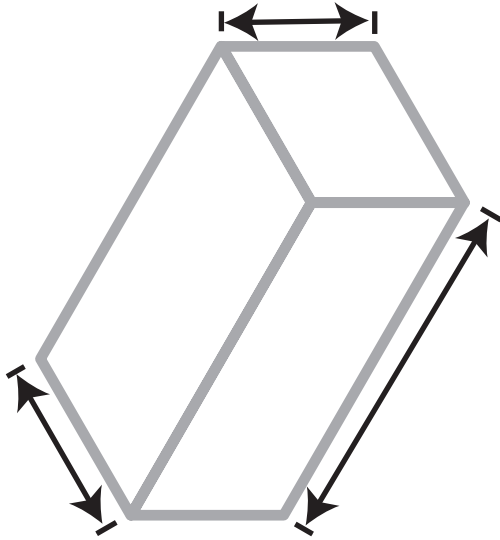
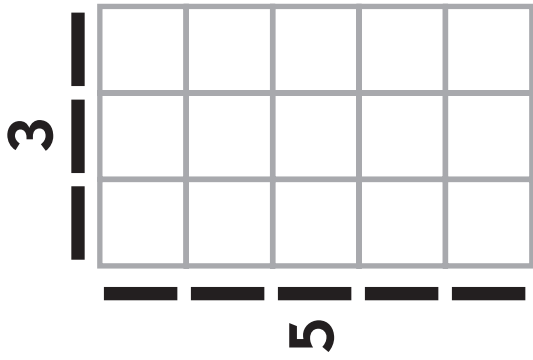

dimension

Bridges in Mathematics

© The Math Learning Center

Working Definition

dimension: length, width, or depth

Set D6 ★ Activity 2



ACTIVITY

Measuring Perimeter

Overview

Students review the terms area and perimeter, and find the perimeter of a rectangular and a square piece of construction paper. Together, they generate formulas for determining the perimeter of rectangles and squares. Then they apply the information as they work in pairs to find the perimeter of various items around the classroom.

Skills & Concepts

- ★ determine the perimeters and areas of squares and other rectangles using formulas and explain why the formulas work

Recommended Timing

Anytime after Set D6 Activity 1

You'll need

- ★ Measuring Perimeter (page D6.12, class set)
- ★ 9" × 12" green construction paper (half class set)
- ★ one 12" × 12" piece of red construction paper
- ★ base 10 mats available
- ★ geoboards available
- ★ rulers (class set)
- ★ yardsticks and measuring tapes
- ★ Student Math Journals or 1 piece of lined or grid paper per student
- ★ Word Resource Cards *Area, Perimeter* (pages D6.5 and D6.6 & D6.13 and D6.14, run 1 copy back to back on cardstock, cut out each card)

Instructions for Measuring Perimeter

1. Post the Word Resource Cards for *area* and *perimeter* on the board. Ask student pairs to compare and contrast the two terms. How are they alike? How are they different? After a minute or two, invite volunteers to share their ideas with the class. As the discussion unfolds, review the following concepts:

- area and perimeter are both measurements.
- area is a measure of how much surface something takes up.
- area is measured in square units such as square inches, square feet, or square miles.
- perimeter is a measure of the total distance around something.
- perimeter is measured in linear units such as inches, feet, yards, or miles.

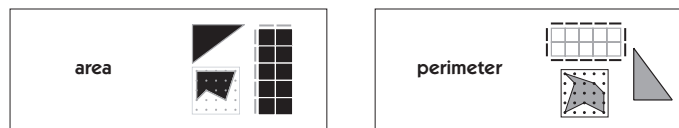

2. Explain that you'll be working with perimeter today. Have students pair up or assign partners, and ask them to get out their rulers and math journals. Give each pair a 9" × 12" sheet of construction paper without mentioning the dimensions. Ask them to use the inch side of their ruler to find the perimeter, or the total distance around the paper. Have them each record the answer, along with any computations they made, in their journals.

Activity 2 Measuring Perimeter (cont.)

3. When they've had a couple of minutes to work, ask students to share their answers and explain how they found the perimeter of the paper. Use numbers and labeled sketches to record the strategies they share.

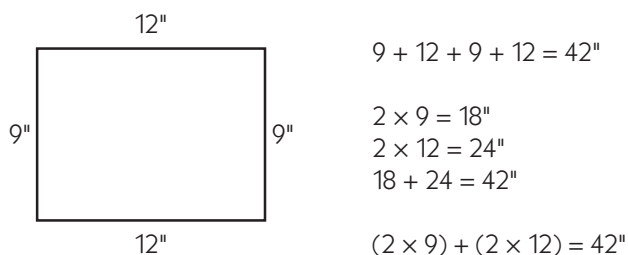

4. Chances are, some students will have added all 4 side lengths, while others may have multiplied each of the lengths by 2 and then added. If the second strategy doesn't come from the students, model it yourself. Then work with input from the class to write a general formula for finding the perimeter of a rectangle: perimeter = $2 \times$ the width + $2 \times$ the length, or $P = 2w + 2l$.

5. Hold up the 12" square of construction paper. Ask students to estimate the perimeter of this square based on the measurements they just made. It's fine if they want to set one of the 9" \times 12" sheets directly on top of the square to help make a more accurate estimate. Record their estimates on the board. Then have a volunteer measure one of the sides of the square and share the measurement with the class. Ask students how they can use that information to find the perimeter. Is it possible to do so without measuring the other 3 side lengths?

Students *Sure! It's a square, so all the sides are the same.*

Just add 12 four times.

Or you could multiply 12×4 to get the answer. It's 48 inches.

6. Work with input from the class to write a general formula for finding the perimeter of a square: perimeter = $4 \times$ the length of one side, or $P = 4s$.

7. Ask students to consider the following question: If there are 12" in a foot, what is the perimeter of the paper square in feet? Have them give the thumbs-up sign when they have the answer and then invite a couple of volunteers to share their thinking.

Students *Each side is a foot, so it's 4 feet all the way around.*

Also, it's 48 inches and $48 \div 12 = 4$, so that's 4 feet.

Wow! That's pretty big around. My little sister isn't much taller than about 4 feet.

8. Explain that in a minute, students will be working in pairs to measure the perimeter of some things around the classroom. Ask them to look around. Can they spot anything they'd measure in inches? What about the calendar grid pocket chart or the whiteboard? Would they find the perimeter of these in inches or feet? Hold up a yardstick and ask them if there's anything in the room with a perimeter it would make most sense to measure in yards.

Students *I'd use inches to find out the perimeter of small stuff like a book or probably my desk.*

I'd definitely use feet instead of inches to get the perimeter of the whiteboard.

I'd use yards to measure the perimeter of the rug or the whole room.

Activity 2 Measuring Perimeter (cont.)

9. Give students each a copy of the Measuring Perimeter worksheet. Examine the chart together and explain the tasks as needed. Ask students if they need to measure the length of every side in order to find the perimeter of their math journal or their desk. Why not?

Make sure they know where to find the yardsticks and measuring tapes as they need them. Then ask them to work in pairs to complete the sheet.

.....
Note Advise students to work to the nearest inch in measuring the side lengths of the items listed on the worksheet.
.....

NAME _____

DATE _____

Measuring Perimeter

Find the perimeter of each item listed below.	Side Lengths (Include units: inches, feet, or yards)	Circle the formula you need to find the perimeter.	Perimeter (Show your work and label the answer with the correct units.)
example A piece of green construction paper	9" and 12"	$P = 2w + 2l$ $P = 4s$	$(2 \times 9) + (2 \times 12) = 42"$
1 Your math journal		$P = 2w + 2l$ $P = 4s$	
2 Your desk or table		$P = 2w + 2l$ $P = 4s$	
3 A geoboard		$P = 2w + 2l$ $P = 4s$	
4 Calendar Grid pocket chart		$P = 2w + 2l$ $P = 4s$	
5 The top of a bookshelf		$P = 2w + 2l$ $P = 4s$	
6 A base 10 mat		$P = 2w + 2l$ $P = 4s$	
7 The whiteboard		$P = 2w + 2l$ $P = 4s$	
8 The classroom		$P = 2w + 2l$ $P = 4s$	

perimeter

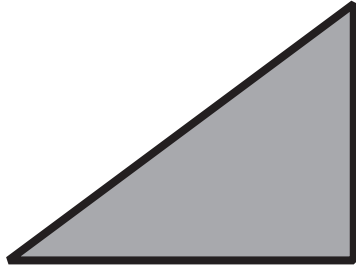
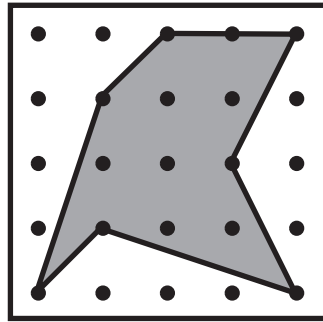
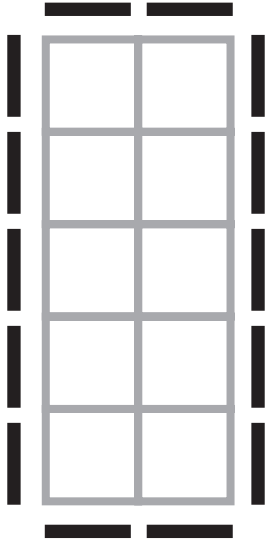

Bridges in Mathematics

© The Math Learning Center

Working Definition

**perimeter: the distance in linear units
around a figure**

Set D6 ★ Activity 3



ACTIVITY

The Ladybugs' Garden

Overview

The Ladybugs are planning their spring garden. They have exactly 24 centimeters of fencing, and they want to make a rectangular garden. Students investigate relationships between area and perimeter as they develop the best plan for the Ladybugs' garden.

Skills & Concepts

- ★ determine the perimeters and areas of squares and other rectangles using formulas and explain why the formulas work
- ★ demonstrate that rectangles with the same area can have different perimeters, and that rectangles with the same perimeter can have different areas
- ★ solve single- and multi-step contextual problems involving perimeters and areas, and justify the solutions

Recommended Timing

Anytime after Set D6 Activity 2

You'll need

- ★ The Ladybugs' Garden (page D6.18, 1 copy on a transparency)
- ★ Centimeter Grid Paper (page D6.19, class set)
- ★ overhead pens
- ★ a piece of paper to mask parts of the overhead
- ★ rulers (class set)

Instructions for The Ladybugs' Garden

1. Give students each a sheet of Centimeter Grid Paper and ask them to get out their pencils and rulers. Show the prompt at the top of the Ladybugs' Garden overhead. Read it with the class and clarify as needed. Give them a few minutes to draw a rectangle on their grid paper that has a perimeter of exactly 24 centimeters.
2. Then invite a volunteer up to the overhead to share his or her work with the class.

Set D6 Measurement: Area & Perimeter Blackline Run 1 copy on a transparency.

The Ladybugs' Garden

1 The Ladybugs are planning to plant a garden this spring. They want it to be rectangular. They have exactly 24 centimeters of fencing put around the perimeter of their garden. Sketch a plan for them on your grid paper.

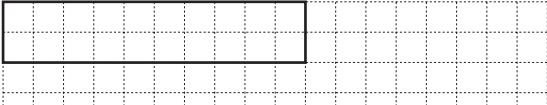

Beckett *I started by drawing a line that was 10 centimeters along the top. That just seemed like a good length. Then I drew 2 centimeters down. That added up to 12, and I realized that it would take 12 more to make the rest of the rectangle. It turned out kind of skinny, but it worked.*

Activity 3 The Ladybugs' Garden (cont.)

3. Have your volunteer label each side of his or her rectangle with its length and sit down again. Then ask the rest of the class to write 2 equations on the back of their grid paper, one for the perimeter and one to determine the area of the rectangle. Remind them to label their answers with the correct units. Have them pair-share their work as they finish. Work with input from the class to label the rectangle with its area and write the two needed equations at the overhead. Take the opportunity to review the formulas for finding the perimeter and area of a rectangle, and ask students to correct their work if necessary.

Set D6 Measurement: Area & Perimeter Blackline Run 1 copy on a transparency.

The Ladybugs' Garden

1 The Ladybugs are planning to plant a garden this spring. They want it to be rectangular. They have exactly 24 centimeters of fencing put around the perimeter of their garden. Sketch a plan for them on your grid paper.

A grid showing a rectangle with a length of 10 cm and a width of 2 cm. The perimeter is labeled as 24 cm and the area as 20 sq cm. To the right of the grid, the following equations are written:

$$P: (2 \times 2) + (2 \times 10) = 24 \text{ cm}$$

$$A: 2 \times 10 = 20 \text{ sq cm}$$

4. Have a student who responded differently to the original prompt draw and label his or her rectangle at the overhead. (If no one had a different response, volunteer one of your own.)

Set D6 Measurement: Area & Perimeter Blackline Run 1 copy on a transparency.

The Ladybugs' Garden

1 The Ladybugs are planning to plant a garden this spring. They want it to be rectangular. They have exactly 24 centimeters of fencing put around the perimeter of their garden. Sketch a plan for them on your grid paper.

A grid showing two rectangles. The first rectangle has a length of 10 cm and a width of 2 cm, with a perimeter of 24 cm and an area of 20 sq cm. The second rectangle has a length of 8 cm and a width of 4 cm, also with a perimeter of 24 cm and an area of 20 sq cm. To the right of the grid, the following equations are written:

$$P: (2 \times 2) + (2 \times 10) = 24 \text{ cm}$$

$$A: 2 \times 10 = 20 \text{ sq cm}$$

Delia I started with 8 centimeters along the top and then drew 4 down. I saw that was 12, so I just did the same thing for the bottom and the other side. It's 24 in all.

5. Confirm with the class that both rectangles have a perimeter of 24 centimeters. Even before they calculate the area of the second rectangle, would they say the areas are the same or different?

Students The second one looks bigger.

I'm pretty sure there's more space in the second one.

That's weird because they both have the same amount of fence around the outside.

Activity 3 The Ladybugs' Garden (cont.)

6. Ask students to write 2 equations for the second rectangle on the back of their grid paper, one for the perimeter and one for the area. Then work with their input to label the second rectangle with its area and write both equations at the overhead. Is the area of the second rectangle the same as the first or different? Ask students to pair share ideas about why the areas are different even though the perimeters are the same. Then invite volunteers to share their thinking with the class.

Students *The one that's long and skinny doesn't have as much area.
It's like when you make the sides shorter, you get more room in the middle.
The first rectangle I drew has even more space in the middle.*

7. Then reveal the rest of the overhead. Read it with the class and clarify as needed. Let them know that they need to find at least 4 different rectangles, and it's fine if one is a square because squares are also rectangles. Make sure students understand that a 2×10 and a 10×2 don't count as 2 different rectangles. Ask them to respond to questions 3 and 4 on the back of their grid paper.

- 2** Now sketch as many different rectangles as you can find that have a perimeter of 24 centimeters. Label each one with its perimeter and area, along with equations to show how you got the answers. Note: The sides of your rectangle must lie on the grid lines.
- 3** All of your rectangles have a perimeter of 24 centimeters. Do they all have the same area? Why or why not?
- 4** Which rectangle would work best for the Ladybugs' garden? Explain your answer.

8. When most students have finished, reconvene the class to share and compare their results. They'll find that there are 6 different rectangles with a perimeter of 24 cm: 1×11 , 2×10 , 9×3 , 8×4 , 7×5 , and 6×6 . Each has a different area (11 sq cm, 20 sq cm, 27 sq cm, 32 sq cm, 35 sq cm, and 36 sq cm respectively), the square having the most. Encourage students to continue to explain why the areas vary from one rectangle to the next. (The closer rectangles with the same perimeter get to being square, the larger their area. Some students may be interested to know that a circle is the shape that has the maximum area for any given perimeter.) Also encourage students to discuss and debate the best rectangle for the Ladybugs' garden. Some may feel that the 6×6 is best because it offers the most space. Others may believe that the 3×9 or 4×8 is better because it's easier to water all the plants, including ones in the middle.

**INDEPENDENT WORKSHEET**

See Set D6 Independent Worksheets 1 and 2 for more practice selecting and using appropriate units and formulas to determine area and perimeter.

The Ladybugs' Garden

1 The Ladybugs are planning to plant a garden this spring. They want it to be rectangular. They have exactly 24 centimeters of fencing put around the perimeter of their garden. Sketch a plan for them on your grid paper.

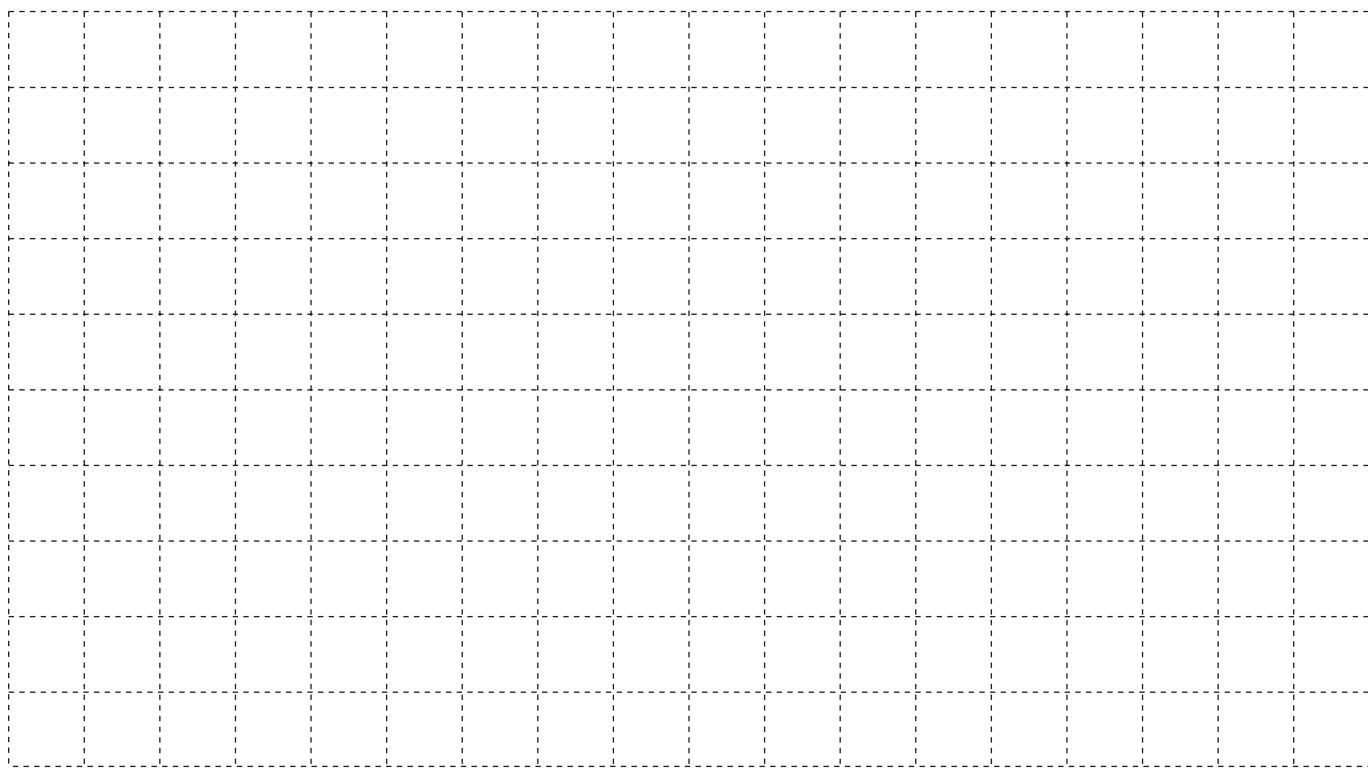

2 Now sketch as many different rectangles as you can find that have a perimeter of 24 centimeters. Label each one with its perimeter and area, along with equations to show how you got the answers. Note: The sides of your rectangle must lie on the grid lines.

3 All of your rectangles have a perimeter of 24 centimeters. Do they all have the same area? Why or why not?

4 Which rectangle would work best for the Ladybugs' garden? Explain your answer.

NAME _____

DATE _____

Centimeter Grid Paper

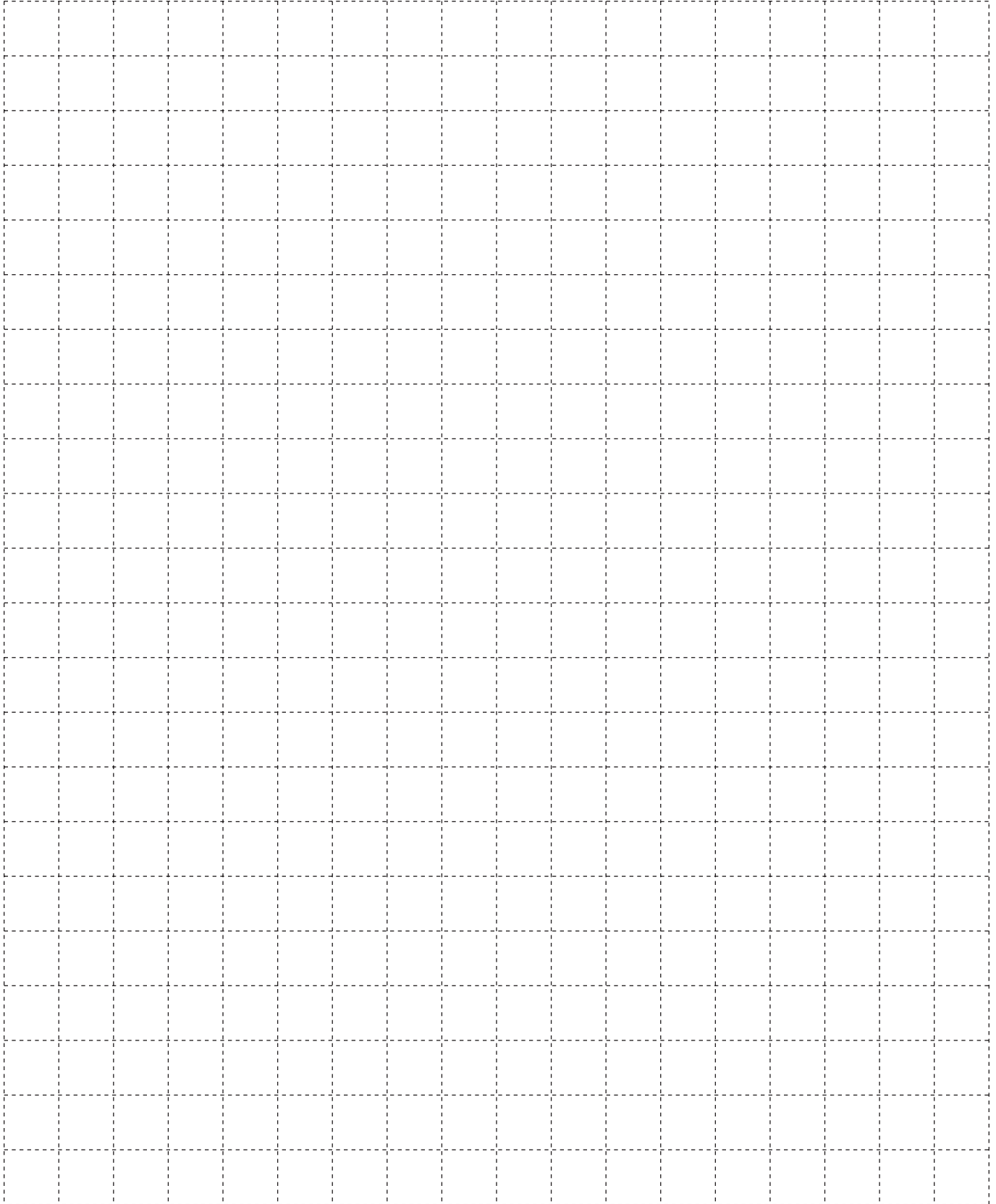

Set D6 ★ Activity 4



ACTIVITY

Hexarights

Overview

Students continue to investigate relationships between area and perimeter as they measure and construct polygons called “hexarights” (hexagons with pairs of adjacent sides that meet at right angles).

Skills & Concepts

- ★ determine the perimeters and areas of squares and other rectangles using formulas and explain why the formulas work
- ★ determine the areas of nonrectangular figures that can be composed or decomposed into rectangles
- ★ demonstrate that rectangles with the same area can have different perimeters, and that rectangles with the same perimeter can have different areas
- ★ solve single- and multi-step contextual problems involving perimeters and areas, and justify the solutions

Recommended Timing

Anytime after Set D6 Activity 2

You'll need

- ★ Introducing Hexarights (page D6.24, 1 copy on a transparency)
- ★ Measuring Hexarights (page D6.25, half-class set, cut in half)
- ★ Hexarights, Perimeter = 24 cm (page D6.26, class set)
- ★ Centimeter Grid Paper (page D6.27, class set, plus a few extra)
- ★ piece of paper to mask parts of the overhead
- ★ 2 or 3 transparencies and overhead pens
- ★ rulers marked with both centimeters and inches (class set)

Instructions for Hexarights

1. Show the top portion of Introducing Hexarights at the overhead, masking the rest with a piece of paper. Give students a minute to pair-share any observations they can make. Then invite volunteers to share their thinking with the class. Record some of their ideas in the space to the left of the shape.
2. Then reveal the definition below the shape, still keeping the rest of the overhead covered. Read and discuss it with the class. As you do so, review the meanings of the terms *hexagon*, *perpendicular*, and *right angles*.

Set D6 Measurement: Area & Perimeter Blackline Run 1 copy on a transparency.

Introducing Hexarights

1 Describe this shape.

- has 6 sides
- has 5 maybe 6 right angles
- has parallel lines
- some of the lines are perpendicular
- kind of like 2 rectangles stuck together
- none of the lines are the same length

This shape is a hexagon because it has 6 sides, but let's call it a *hexaright*. A *hexaright* is a hexagon in which sides that touch each other is perpendicular (That is, they meet at right angles.)

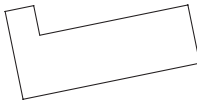

Activity 4 Hexarights (cont.)

3. Next, reveal the two counter-examples shown in the middle of the overhead. Can students explain why neither of these are hexarights? Have them share at the overhead so their classmates can see what they're talking about.

Set D6 Measurement: Area & Perimeter Blackline Run 1 copy on a transparency.

Introducing Hexarights

1 Describe this shape.

- has 6 sides
- has 5 maybe 6 right angles
- has parallel lines
- some of the lines are perpendicular
- kind of like 2 rectangles stuck together
- none of the lines are the same length

This shape is a hexagon because it has 6 sides, but let's call it a *hexaright*. A *hexaright* is a hexagon in which sides that touch each other is perpendicular (That is, they meet at right angles.)

2 Here are 2 examples of shapes that are *not* hexarights. Can you see why?

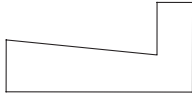
a 

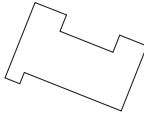
b 

Students *Shape a isn't a hexaright because there are 2 angles that aren't right angles.*

I thought they were wrong about shape b because it's all right angles, but then I realized there are 10 sides! A hexaright can only have 6 sides.

4. Now show the 2 hexarights at the bottom of the overhead and briefly discuss strategies for finding the area and perimeter of each. Then give students each a copy of the Measuring Hexarights half-sheet. Ask them to experiment with both the inch side and the centimeter side of their rulers. Which unit of measure works best? Students will quickly discover that most of the measurements don't come out evenly unless they use centimeters.

5. Solicit agreement from the class that they'll work in centimeters and square centimeters rather than inches and square inches, and let them get started. Encourage them to share and compare their strategies and solutions as they work.

6. When most students have finished finding the perimeter and area of at least one of the hexarights, place a blank transparency on top of the overhead and invite volunteers to share their work with the class. Move or replace the transparency each time a new volunteer comes up to the overhead to accommodate several different presentations. Here is an example of the sort of work you might expect from students, although some will divide the hexarights differently.

Activity 4 Hexarights (cont.)

Set D6 Measurement: Area & Perimeter Blackline Run a half-class set and cut the sheets in half.
 Name _____ Date _____

Measuring Hexarights

Find the area and perimeter of the hexarights below. Show all your work.

Hexaright 1:
 Dimensions: 6 cm, 4 cm, 2 cm, 3 cm, 2 cm, 3 cm
 Area: $2 \times 3 = 6 \text{ sq cm}$
 $3 \times 4 = 12 \text{ sq cm}$
 Perimeter: $6 + 2 + 3 + 3 + 4 = 18 \text{ cm}$
 $P = 18 \text{ cm}$ $A = 18 \text{ sq cm}$

Hexaright 2:
 Dimensions: 1 cm, 8 cm, 4 cm, 1 cm, 3 cm, 7 cm
 Area: $1 \times 7 = 7 \text{ sq cm}$
 $1 \times 4 = 4 \text{ sq cm}$
 Perimeter: $1 + 8 + 4 + 1 + 3 + 7 = 24 \text{ cm}$
 $P = 24 \text{ cm}$ $A = 11 \text{ sq cm}$

7. As students share, discuss the methods they’re using to find the area and perimeter of these shapes. Did they use the perimeter formulas they developed during Set D6 Activity 2? Why not? (Because these are irregular polygons. All you can do is simply add all the different side lengths.) Did they use the area formula they developed during Measurement—Area Perimeter Activity 1? How? (To find the area without covering the shape with centimeter square units or drawing them in, you need to divide each hexaright into 2 rectangles. Then you can use $A = lw$ to find the area of each rectangle and add these areas to get the area of the hexaright.)

8. After 2 or 3 strategies have been shared for each hexaright, explain that there is more than one hexaright with a perimeter of 24 centimeters. Give students each a copy of Hexarights, Perimeter = 24 cm. Review the instructions together and clarify as needed. Place a small stack of the Centimeter Grid Paper on each table and give students the remainder of the math period to work. Encourage them to share and compare their strategies for finding other hexarights with perimeters equal to 24 centimeters. What are some of the areas that result? Are they all equal?

Set D6 Measurement: Area & Perimeter Blackline Run a class set.
 NAME _____ DATE _____

Hexarights, Perimeter = 24 cm

- 1 Draw 2 *different* hexarights with a perimeter of 24 cm, and find the area of each. Then draw a third hexaright with a perimeter of 24 cm. This time, make the area as large as you can.
- 2 You can use the space below and the back of this sheet. Or, you can draw your hexarights on centimeter grid paper, cut them out, and glue them to this sheet. Use your ruler to help make the lines straight and accurate.
- 3 Label your hexarights with their dimensions, perimeter, and area. Use numbers, sketches, and/or words to show how you found the perimeter and area of each hexaright.
- 4 On the back of the sheet, write at least 2 sentences to describe what you found out about the areas of hexarights with a perimeter of 24 cm.

Reconvene the class to share strategies and solutions either at the end of the period or at another time.

Note “Hexaright” is not some long-forgotten concept from your high school geometry days. It is a made-up term borrowed from Measuring Up: Prototypes for Mathematics Assessment (Mathematical Sciences Education Board National Research Council, 1993. Washington, DC: National Academy Press). You may want to let students know this so that they won’t expect to see, or use it on standardized texts.

Introducing Hexarights

1 Describe this shape.

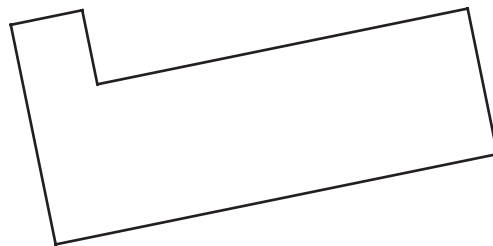

This shape is a hexagon because it has 6 sides, but let's call it a *hexaright*. A *hexaright* is a hexagon in which sides that touch each other are perpendicular. (That is, they meet at right angles.)

2 Here are 2 examples of shapes that are *not* hexarights. Can you see why?

a

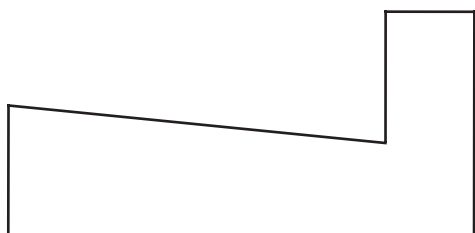

b

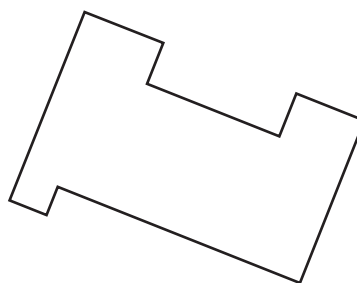

3 Find the area and perimeter of the hexarights below.

a

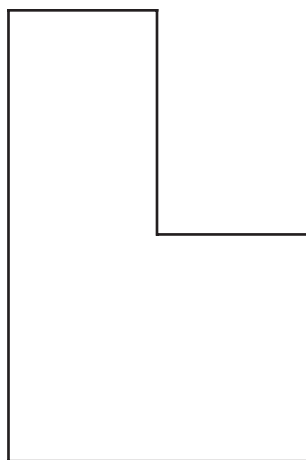

b

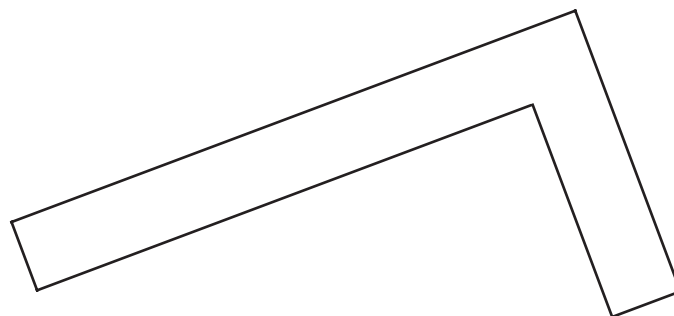

NAME _____

DATE _____

Measuring Hexarights

Find the area and perimeter of the hexarights below. Show all your work.

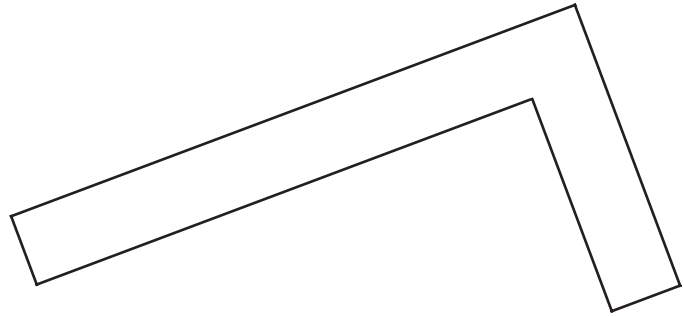
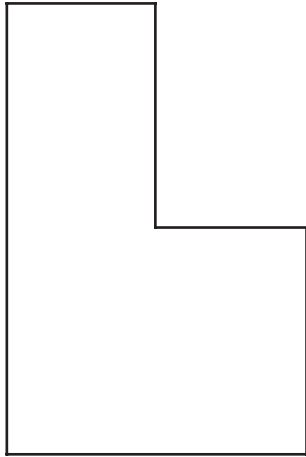

NAME _____

DATE _____

Measuring Hexarights

Find the area and perimeter of the hexarights below. Show all your work.

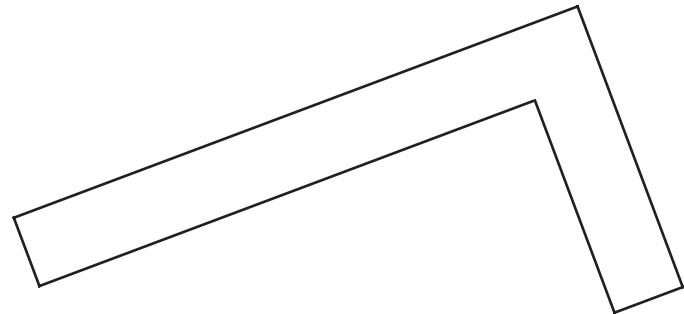
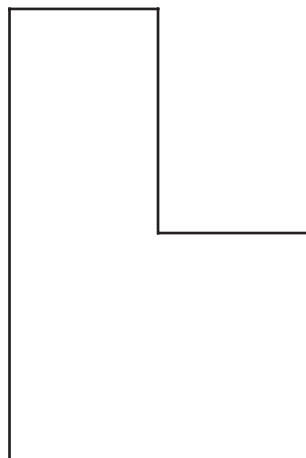

NAME _____

DATE _____

Hexarights, Perimeter = 24 cm

- 1** Draw 2 *different* hexarights with a perimeter of 24 cm, and find the area of each. Then draw a third hexaright with a perimeter of 24 cm. This time, make the area as large as you can.
- 2** You can use the space below and the back of this sheet. Or, you can draw your hexarights on centimeter grid paper, cut them out, and glue them to this sheet. Use your ruler to help make the lines straight and accurate.
- 3** Label your hexarights with their dimensions, perimeter, and area. Use numbers, sketches, and/or words to show how you found the perimeter and area of each hexaright.
- 4** On the back of the sheet, write at least 2 sentences to describe what you found out about the areas of hexarights with a perimeter of 24 cm.

NAME _____

DATE _____

Centimeter Grid Paper

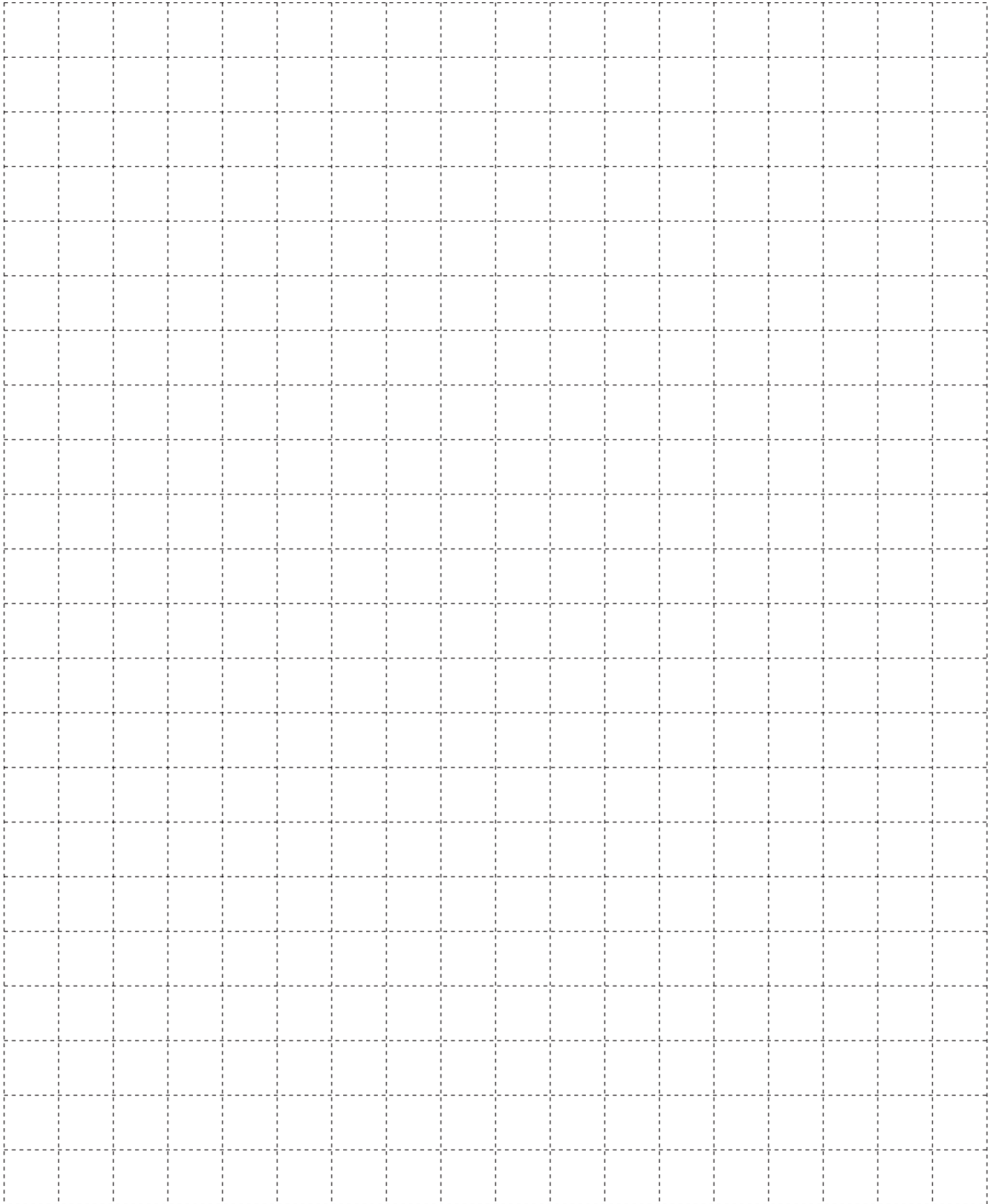

NAME _____

DATE _____

Set D6 ★ Independent Worksheet 1



INDEPENDENT WORKSHEET

Area & Perimeter Review

Perimeter is the distance all the way around a figure. Perimeter is measured in linear units like centimeters, meters, inches, feet, and yards.

Area is the amount of surface a figure covers. Area is measured in square units like square centimeters, square meters, square inches, square feet, and square yards.



Area

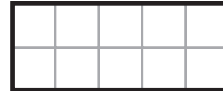

Perimeter

1 Use the centimeter side of your ruler to measure the dimensions (the length and width) of each rectangle on the next page. Then find its area and perimeter using the formulas below. Show your work.

- Perimeter = $(2 \times \text{the width}) + (2 \times \text{the length})$ or $P = (2 \times w) + (2 \times l)$
- Area = length \times width or $A = l \times w$

example

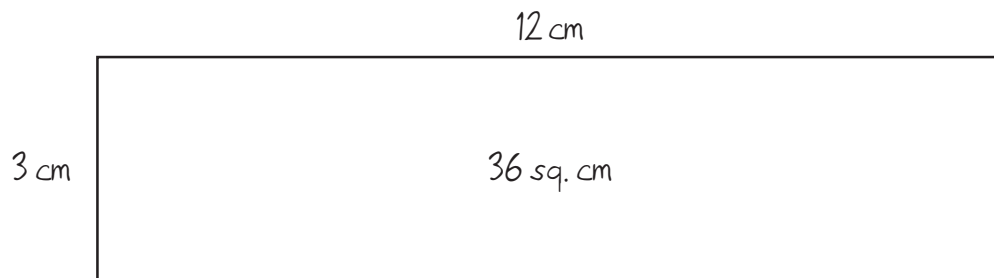



Perimeter: $(2 \times 3) + (2 \times 12) = 30 \text{ cm}$

Area: $12 \times 3 = 36 \text{ sq. cm}$

(Continued on back.)

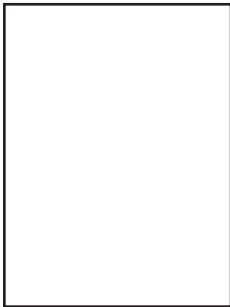
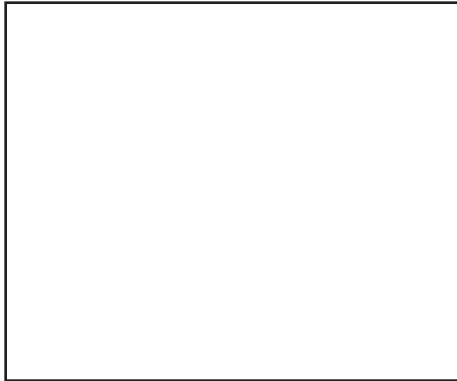
Independent Worksheet 1 Area & Perimeter Review (cont.)

<p>a</p>  <p>Perimeter: Area:</p>	<p>b</p>  <p>Perimeter: Area:</p>
<p>c</p>  <p>Perimeter: Area:</p>	<p>d</p>  <p>Perimeter: Area:</p>

2 Jamie says you only need to measure one side of a square to find its perimeter. Do you agree with her? Why or why not? Use numbers, labeled sketches, and words to explain your answer.

(Continued on next page.)

NAME _____

DATE _____

Independent Worksheet 1 Area & Perimeter Review (cont.)

3 Hector says you have to measure the length of every side of this figure to find its perimeter. Do you agree with him? Why or why not? Use numbers, labeled sketches, and words to explain your answer.

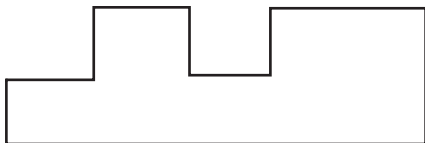

4 Which equation shows how to find the perimeter of this rectangle?

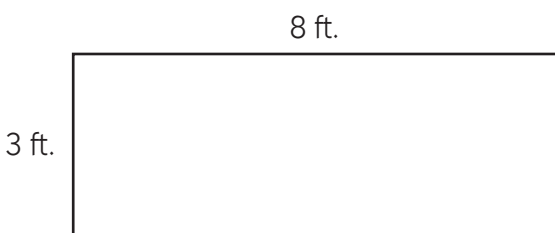

- $3 \times 8 = 24$ ft.
- $(2 \times 3) + 8 = 14$ ft.
- $(2 \times 3) + (2 \times 8) = 22$ ft.
- $4 + 8 = 12$ ft.

5 Mr. Hunter is trying to find the distance from one end of his whiteboard to the other. Mr. Hunt is measuring:



- the board's area
- the board's length
- the board's perimeter

6 Which of these situations is about perimeter?

- determining the number of tiles needed to cover a floor
- determining how many feet of fencing is needed to surround a rectangular yard
- determining the width of a table

7 Beckett and his mom are going to paint the living room. They need to measure the room so they know how much paint to buy. They should measure the wall in:

- square centimeters
- square feet
- square inches
- square miles

(Continued on back.)

Independent Worksheet 1 Area & Perimeter Review (cont.)

8 This rectangle has an area of 45 square feet. What is the missing measure? Show your work.

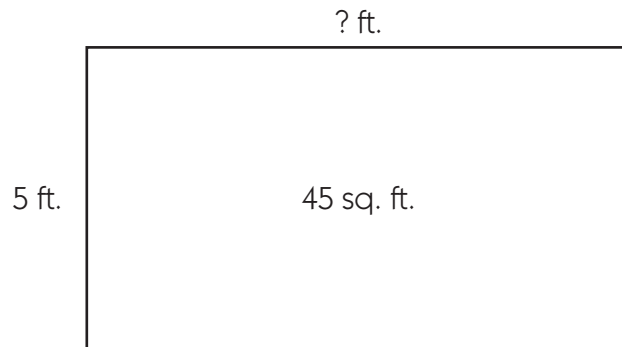

9 Tom wants to find the area of his school's basketball court. Which formula should he use? (circle one)

$A = l + w$
 $A = l \times w$
 $A = l - w$
 $A = (2 \times w) + (2 \times l)$

10 Alexandra and her dad build a deck in their backyard. It had an area of 48 square feet and a perimeter of 28 feet. Circle the drawing that shows the deck they built. Use numbers, labeled sketches, and words to explain your answer.

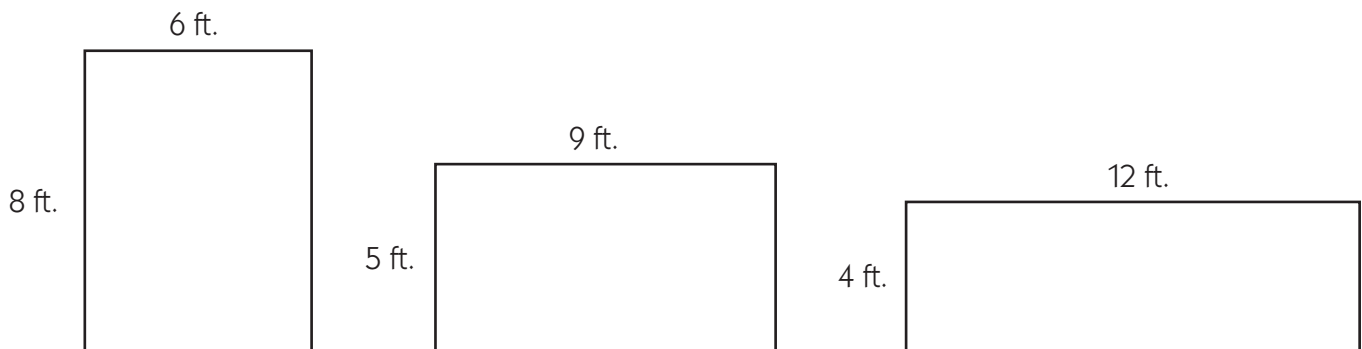

NAME _____

DATE _____

Set D6 ★ Independent Worksheet 2



INDEPENDENT WORKSHEET

Measuring Rectangles

1a Which formula shows how to find the area of this rectangle?

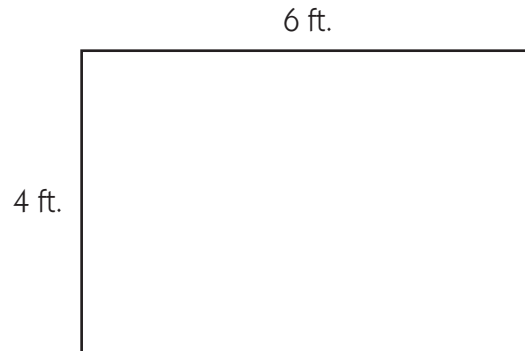

Area =
 $(2 \times \text{width}) + (2 \times \text{length})$
 $A = 2w + 2l$

Area =
 length + width
 $A = l + w$

Area =
 length \times width
 $A = l \times w$

b Use the formula you selected to find the area of the rectangle. Show your work.

2a Which formula shows how to find the perimeter of this rectangle?

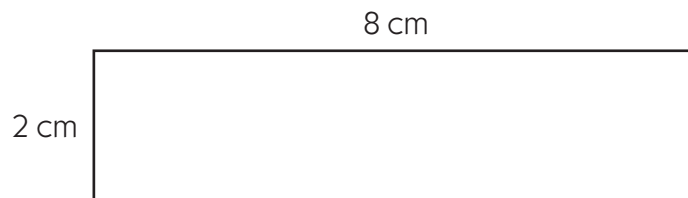

Perimeter =
 $(3 \times \text{width}) + (3 \times \text{length})$
 $P = w + 3l$

Perimeter =
 length \times width
 $P = l \times w$

Perimeter =
 length + width
 $P = l + w$

Perimeter =
 $(2 \times \text{width}) + (2 \times \text{length})$
 $P = 2w + 2l$

(Continued on back.)

Independent Worksheet 2 Measuring Rectangles (cont.)

2b Use the formula you selected to find the perimeter of the rectangle. Show your work.

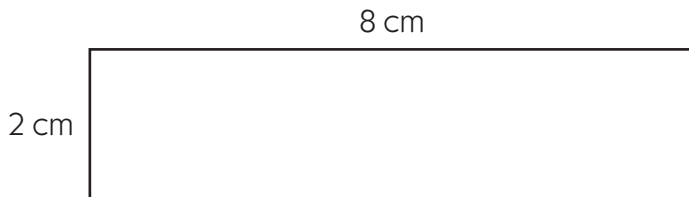

3a Which formula shows how to find the area of this rectangle?

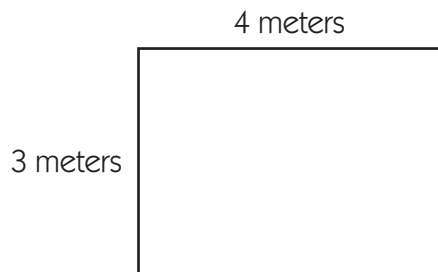

Area =
length \div width
 $A = l \div w$

Area =
length \times width
 $A = l \times w$

Area =
length $-$ width
 $A = l - w$

Area =
length $+$ width
 $A = l + w$

b Use the formula you selected to find the area of the rectangle. Show your work.

(Continued on next page.)

NAME _____

DATE _____

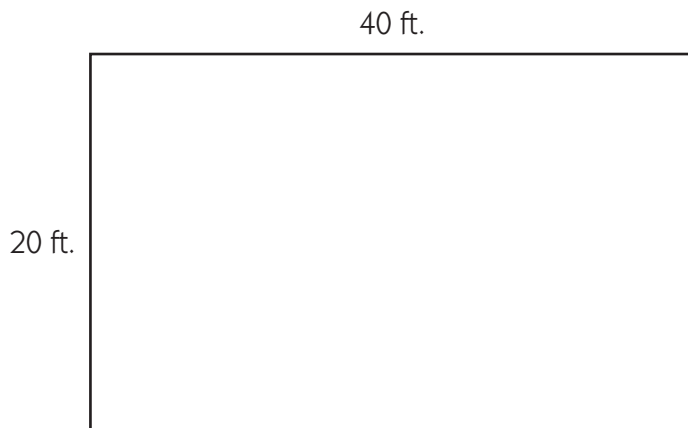
Independent Worksheet 2 Measuring Rectangles (cont.)**4a** Which formula shows how to find the perimeter of this rectangle?

Perimeter =
 $(2 \times \text{width}) + (2 \times \text{length})$
 $P = 2w + 2l$

Perimeter =
 $\text{length} \times \text{width} \times \text{height}$
 $P = l \times w \times h$

Perimeter =
 $\text{length} \times \text{width}$
 $P = l \times w$

Perimeter =
 $(2 \times \text{width}) - \text{length}$
 $P = 2w - l$

b Use the formula you selected to find the perimeter of the rectangle. Show your work.

