



GRADE 1 SUPPLEMENT

Set D2 Measurement: Length in Non-Standard Units

Includes

Activity 1: Measuring Length with Popsicle Sticks	D2.1
Activity 2: Measuring Length with Unifix Cubes	D2.5
Activity 3: How Long is the Jump Rope?	D2.11

Skills & Concepts

- ★ estimate and measure using non-standard units
- ★ measure with multiple copies of units of the same size
- ★ demonstrate an understanding that using different measurement units will result in different numerical measurements for the same object

Bridges in Mathematics Grade 1 Supplement

Set D2 Measurement: Length in Non-Standard Units

The Math Learning Center, PO Box 12929, Salem, Oregon 97309. Tel. 1 800 575–8130.

© 2013 by The Math Learning Center

All rights reserved.

Prepared for publication on Macintosh Desktop Publishing system.

Printed in the United States of America.

P201304

The Math Learning Center grants permission to classroom teachers to reproduce blackline masters in appropriate quantities for their classroom use.

Bridges in Mathematics is a standards-based K–5 curriculum that provides a unique blend of concept development and skills practice in the context of problem solving. It incorporates the Number Corner, a collection of daily skill-building activities for students.

The Math Learning Center is a nonprofit organization serving the education community. Our mission is to inspire and enable individuals to discover and develop their mathematical confidence and ability. We offer innovative and standards-based professional development, curriculum, materials, and resources to support learning and teaching. To find out more, visit us at www.mathlearningcenter.org.

Set D2 ★ Activity 1



ACTIVITY

Measuring Length with Popsicle Sticks

Overview

Students use popsicle sticks to estimate and measure the length of different objects around the room.

Skills & Concepts

- ★ estimate and measure using non-standard units
- ★ measure with multiple copies of units of the same size

You'll need

- ★ How Long Is It? Measuring with Popsicle Sticks, sheets 1 and 2 (pages D2.3 and D2.4, half-class set plus a few extra, see Advance Preparation)
- ★ 4 to 6 baskets of popsicle sticks
- ★ piece of chart paper (or space on the whiteboard)
- ★ markers

.....

Advance Preparation Run a half-class set of both sheets (pages D2.3 and D2.4) plus a few extra. Cut the sheets in fourths along the lines. Collate and staple each set in the upper left corner to make a half-class set of 8-page mini-booklets plus one for yourself and a few extra in case you need them later.

.....

Instructions for Measuring Length with Popsicle Sticks

1. Before you gather students to the discussion circle, post a piece of chart paper on an easel where you can reach it, or clear a similar amount of space on your whiteboard if that's more accessible. You'll also need a basket of popsicle sticks and the measuring booklets you've prepared to introduce the activity. Invite students to join you in the circle, and explain that you're going to measure length with popsicle sticks today. Then choose a volunteer from the group to be your helper.

***Teacher** Boys and girls, today we're going to use popsicle sticks to measure how long some of the things in our classroom are. I'm going to reach into my box and pull out someone's name to be a helper for the first part of the lesson. Esteban, your name came out. Are you willing to help?*

2. Have your helper lie down in the middle of the circle and ask the children to whisper to their neighbors how many popsicle sticks placed end-to-end they think it will take to measure the length of their classmate, from his heels to the top of his head. Have students volunteer estimates as you record them on the chart paper or whiteboard.

3. Lay out popsicle sticks end-to-end beside your helper, working from his heels up to his head, as the other students watch. Leave a large gap between 2 of the sticks as you work. Most likely, the children will say something about this immediately. If they don't, ask them to comment. Is it okay to leave spaces between some of the sticks? Why or why not?

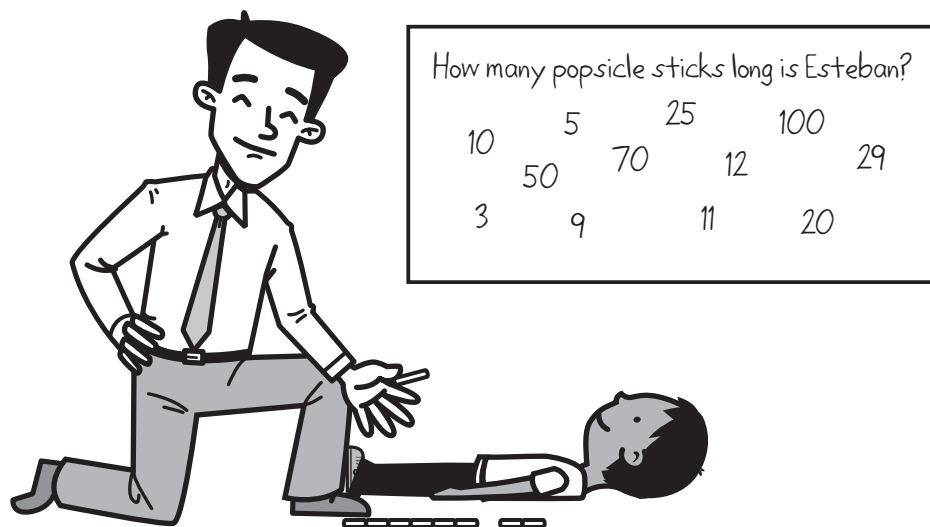
Activity 1 Measuring Length with Popsicle Sticks (cont.)

Darryl Hey wait! You can't leave a hole like that!

Teacher Why not?

Jasmine If you leave holes, you don't get the right answer. The things have to touch each other, and you have to make them straight, too.

4. After some discussion, adjust the sticks so they're laid out correctly and continue until the line stretches from your helper's heels to his head. (If the last stick goes over a little, that's okay.) Then have your helper sit back down in the circle. Ask students if they think there are any estimates that can be eliminated from the chart before you count the sticks, and work with their suggestions to cross those out.



Teacher Before we count the sticks, let's look at the chart again. Do you think there are any estimates that are way too big or way too small? If you do, we'll cross them out.

Students I think 100 is way too much. There aren't 100 sticks up there.

Five is too small. I already counted them, and there are 12.

Three isn't enough. There are way more than 3 there.

5. Count the popsicle sticks with the children to determine the actual length of your helper. If the number is among those already on the board, circle it and cross out the rest. If not, cross out all the estimates and record the actual number of sticks on the board.

6. Show students the mini-booklets you've prepared. Explain that they will work in partners to measure things around the room with popsicle sticks. On each page, they'll need to estimate how many sticks it will take to measure the length of the item shown, record the estimate, lay out sticks beside the item without leaving any gaps or holes, count the sticks to find the actual length, and record the total.

7. Once students understand what to do, have helpers set baskets of popsicle sticks around the room and send pairs out to work. Give the children as much time to work as you have available right now. Have them complete their booklets during Work Places over the next few days.

NAME _____

DATE _____

How Long Is It? Measuring with Popsicle Sticks

 page 1 of 2

How long is it?

Measuring with popsicle sticks



by _____

and _____

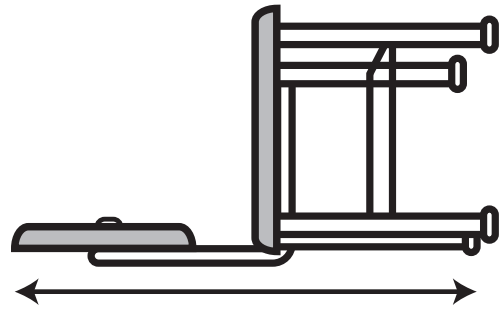

a chair



guess



check

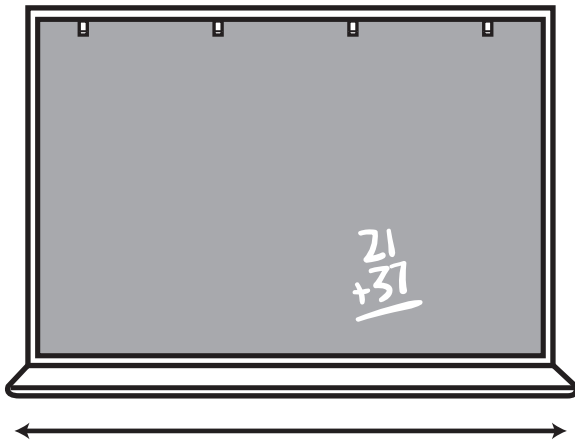

a whiteboard



guess

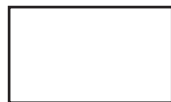

check

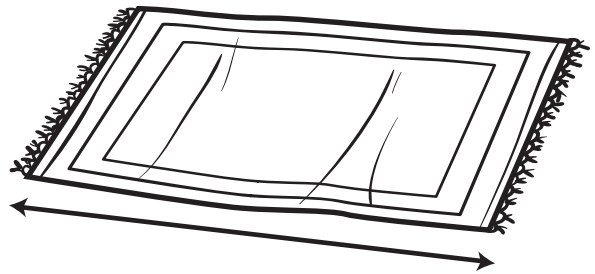

a rug

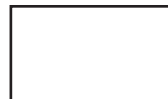

guess

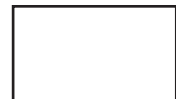

check

NAME _____

DATE _____

How Long Is It? Measuring with Popsicle Sticks page 2 of 2



a bookshelf

guess

check

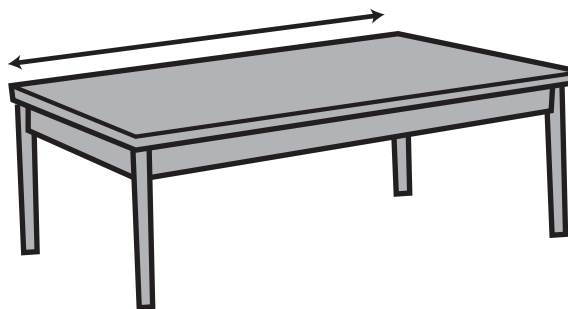

a table

guess

check

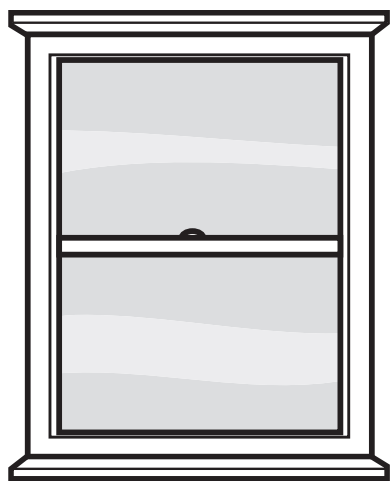

a window

guess

check

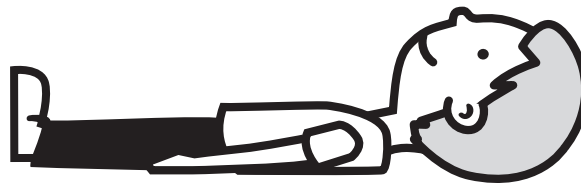

a friend

guess

check

Set D2 ★ Activity 2



ACTIVITY

Measuring Length with Unifix Cubes

Overview

Students use Unifix cubes to estimate and measure the length of different objects around the room.

Skills & Concepts

- ★ estimate and measure using non-standard units
- ★ measure with multiple copies of units of the same size
- ★ demonstrate an understanding that using different measurement units will result in different numerical measurements for the same object

You'll need

- ★ How Long Is It? Measuring with Unifix Cubes, sheets 1 and 2 (pages D2.8 and D2.9, half-class set plus a few extra, see Advance Preparation)
- ★ 7 or 8 trains of 10 Unifix cubes plus 10 single cubes (see Advance Preparation)
- ★ 4–6 baskets or tubs of Unifix cubes
- ★ piece of chart paper (or space on the whiteboard)
- ★ popsicle sticks
- ★ markers

Advance Preparation Build each train with 10 cubes of the same color, but make each train a different color than the rest. The 10 single cubes should be a single color as well. Run a half-class set of both sheets plus a few extra. Cut the sheets in fourths along the lines. Collate and staple each set in the upper left corner to make a half-class set of 8-page mini-booklets plus one for yourself and a few extra in case you need them later.

Note Students will use standard units to measure length in Unit Four, so it would be ideal if you could do this activity and the one that follows before February.

Instructions for Measuring Length with Unifix Cubes

1. Before you gather students to the discussion circle, post a piece of chart paper on an easel where you can reach it, or clear a similar amount of space on your whiteboard if that's more accessible. You'll also need the Unifix cube trains and measuring booklets you've prepared to introduce the activity. Invite students to join you in the circle, and explain that you're going to measure length with Unifix cubes today. Then choose a helper who's roughly the same height as the student you measured with popsicle sticks in Set D2 Activity 1.

2. Tell the class that you're going to snap together enough Unifix cubes to make a train the same length as your helper. Recall with them that you measured a different helper with popsicle sticks the other day. Have the two helpers stand back-to-back so the children can see they're just about the same height. Then have your new helper lie down in the middle of the circle. Measure her with popsicle sticks, count them with the class, and record the number on the board. Now discuss the following question: Will it

Activity 2 Measuring Length with Unifix Cubes (cont.)

take more or fewer Unifix cubes than popsicle sticks to do the same job? Why? Some children may be able to explain that it will take more cubes than sticks because the cubes are much shorter.

3. Have your helper lie down in the middle of the circle and ask the children to whisper to their neighbors how many cubes they think it will take to make a train that matches her length. Next, count out 10 cubes, all the same color, while the children count with you. Lay the train on the floor so it's level with your helper's heel. Explain that this group of 10 cubes is a *benchmark*, a way to help make a more accurate estimate. Then ask students to volunteer estimates as you record them on the chart paper or whiteboard. (It's fine if you get some very small and very large estimates, despite the fact that you've introduced a benchmark of 10.)

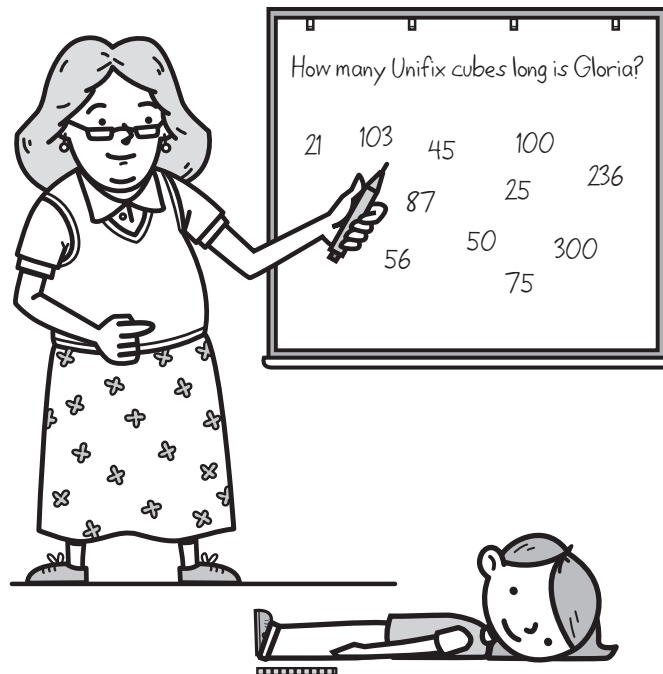

4. Add as many trains as needed to the first one to equal the length of your helper, breaking the last one so that the entire train starts at her heels and ends at her head. Then ask your helper to sit back down in the circle. Ask students if they think there are any estimates that can be eliminated from the chart before you count the cubes, and work with their suggestions to cross those out.



Teacher Before we count the cubes, let's look at the chart again. Do you think there are any estimates that are way too big or way too small? If you do, we'll cross them out.

Students I think it's more than 21 or 25. Gloria's longer than that.
I don't think it's 300. 300 is a really big number. I don't think even Teacher is that big.
I think 236 is too big. That train is smaller than 100, I bet.

Activity 2 Measuring Length with Unifix Cubes (cont.)

5. Break the cubes into 10s and 1s, counting with the students as you break off each train and each of the cubes at the end.



Then point to each of the trains and each of the single cubes and ask students to count them again with you. If students feel the need to count the cubes by 1s “just to make sure,” snap them back together and count them one by one with the class. How does the total compare with the number of popsicle sticks it took to measure your helper? Why did it take more cubes? Would it take more cubes or more popsicle sticks to measure the bookshelf? Why?

6. Show students the mini-booklets you've prepared. Explain that they will work in partners to measure things around the room with Unifix cubes. On each page, they'll need to estimate how many cubes it will take to measure the length of the item shown, record their estimate, build a train the length of the item, count the cubes to find the actual length, and record the total.



7. Once students understand what to do, have helpers set baskets of cubes around the room and send pairs out to work. Give the children as much time to work as you have available right now. Have them complete their booklets during Work Places over the next few days. Encourage them to arrange their cubes in trains of 10 before they measure, but don't insist on it. Even when they do this, many will need to count the cubes one by one to find the totals when working without your direct support, and this is fine.

NAME _____

DATE _____

How Long Is It? Measuring with Unifix Cubes page 1 of 2

How long is it?

Measuring with Unifix cubes



by _____

and _____

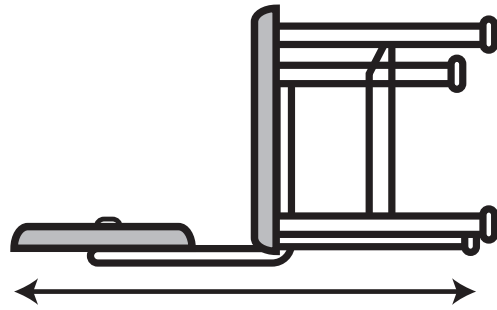

a chair



guess



check

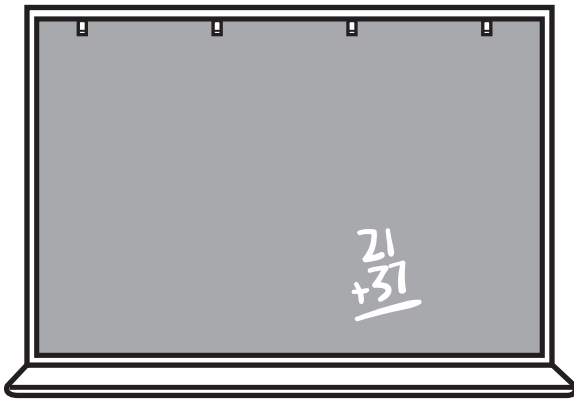

a whiteboard ledge



guess



check

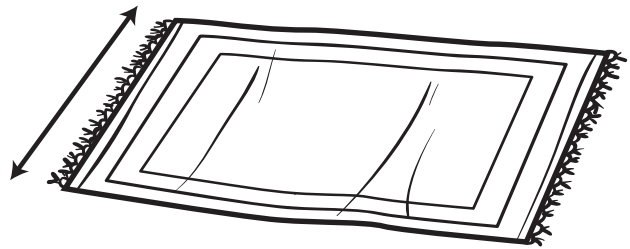

a rug

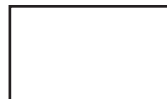

guess

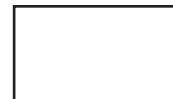

check

NAME _____

DATE _____

How Long Is It? Measuring with Unifix Cubes page 2 of 2

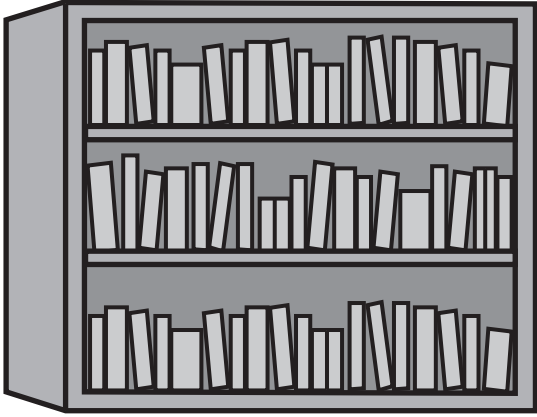

a bookshelf

guess

check

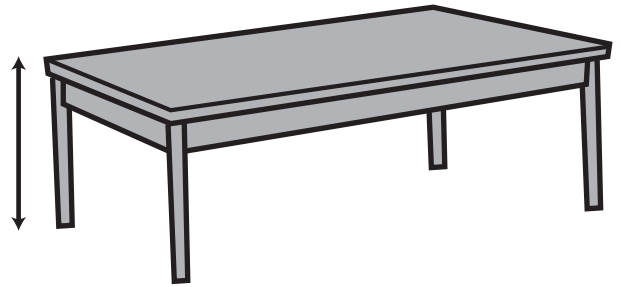

a table

guess

check

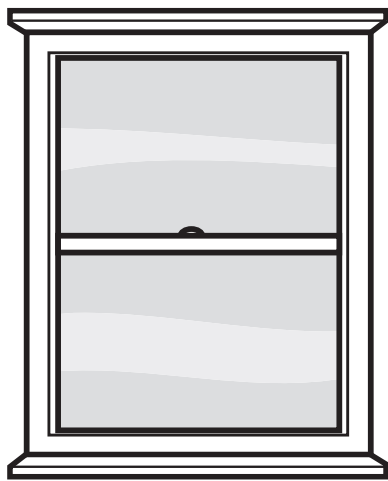

a window

guess

check

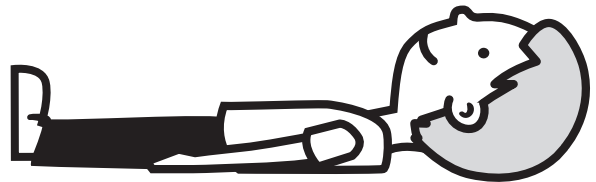

a friend

guess

check

Set D2 ★ Activity 3



ACTIVITY

How Long Is the Jump Rope?

Overview

Students use their feet to estimate and measure the length of a jump rope.

Skills & Concepts

- ★ estimate and measure using non-standard units
- ★ measure with multiple copies of units of the same size
- ★ demonstrate an understanding that using different measurement units will result in different numerical measurements for the same object

You'll need

- ★ a long jump rope (16'–20', borrow one from the gym if necessary)
- ★ 2 pieces of chart paper (or space on the whiteboard) and markers
- ★ *How Big is a Foot?* by Rolf Myller (optional)

Instructions for How Long Is the Jump Rope?

1. Invite students to your discussion circle. Show them the jump rope and then ask a volunteer to help you stretch it out to its full length on the floor as the others watch. Have students move to either side of the rope, leaving plenty of room on both sides.
2. If previous activities, students used popsicle sticks and Unifix cubes to measure length. Explain that in the past, people used their feet to measure length. Today, you're going to use your feet to find out how long the jump rope is. Start at one end of the rope and take 3 or 4 heel-to-toe steps, being careful not to leave any gaps or holes as you walk.



Activity 3 How Long Is the Jump Rope? (cont.)

3. Stop after you've taken 3 or 4 steps and ask students to estimate how long the rope is in teacher steps. Have them whisper their ideas to their neighbors and then raise their hands to share their estimates with the class, as you record on chart paper or the whiteboard.

How long is the jump rope in teacher steps?		
100	25	50
	20	80
200	10	29

4. Start over at one end of the rope and walk about halfway this time, again taking careful heel-to-toe steps as students count with you. Stop around the mid-point and ask students to look at the chart of estimates. Do they see any numbers that could be eliminated? Ask a volunteer to cross out the numbers as his or her classmates make suggestions.

Students *Let's cross out 200. There's no way Mr. Lugo is going to take 200 steps.*

No way for 100 either.

It can't be 10 because he's already gone 10 and there's still more of the rope.

I think it's going to be 20.

5. When some of the estimates have been crossed out, finish measuring the length of the jump rope as students count with you. Record the results on a new piece of chart paper or a different location on the whiteboard. Then choose a volunteer to measure the jump rope in the same manner. Ask this student to estimate how many steps it will take her to measure the rope, and record her guess on the board, using a chart similar to the one shown on the next page.

Teacher *Karina, I've pulled the stick with your name on it out of our feely box. Would you be willing to measure the jump rope with your feet?*

Karina *Sure!*

Teacher *It took me 21 steps to measure the length of the rope. How many steps do you think it will take you?*

Karina *Maybe about 25.*

6. Have your volunteer measure the length of the rope, taking careful heel-to-toe footsteps just like you did. Record the results on your chart and discuss them with the class. More than likely, it took the volunteer more footsteps than you to measure the rope. Why?

7. Repeat steps 5 and 6 with two other volunteers. Discuss the results with the class. Are they the same or different? Why?

Activity 3 How Long Is the Jump Rope? (cont.)

The jump rope is 21 of Mr. Lugo's steps.
How many of your steps will it take to measure the jump rope?

	Guess	Check
Karina	25	40
Hunter	40	35
Bianca	50	42

8. Let students know that you'll extend the chart to include a line for every child, labeled with his or her name. Over the next few days, you'll give each of them a turn to measure the jump rope with their feet, entering an estimate first and then the actual results.

Extensions

- Once the chart described above is complete, discuss it with the class. You might pose some of the following questions:
 - Who took the most steps to measure the jump rope?
 - Who took the fewest?
 - Did anyone get the same answer as someone else in class?
 - Why did children get different answers?
 - Would it work the same way if you measured something else? Why or why not?
- After all the students have had a chance to measure the jump rope, read *How Big is a Foot?* to the class. This book was first published in 1962 and reprinted in 1990. Chances are good you'll find it in your school library. It's a cute story, very accessible to first graders, and helps students understand the need for standard units of measure. It provides a good follow-up to this activity and a nice introduction to the measuring activities in Unit Four, Penguins.

